

CL(T,R)VE1COAX[POE]/M

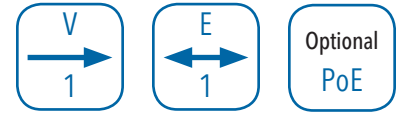

The ComNet™ CL(T,R)VE1COAX[POE]/M is a communications link that combines composite analog baseband video and 10/100T(X) Ethernet on a single RG59 coaxial cable and transmits it up to 500 meters. The device is particularly suited to applications where the addition of IP Video to an existing analog video system is required. The CLTVE1COAXPOE/M model can provide power to the camera via PoE.

FEATURES

- › Simultaneous transmission of IP video, and composite analog video up to 500m over RG59 coaxial cable
- › Proprietary adaptive analog equalizer for extending the reach of composite analog video
- › Full-duplex digital communications
- › Continuous Transmitter to Receiver Ethernet throughput up to 36Mbps
- › Continuous Receiver to Transmitter Ethernet throughput up to 11Mbps
- › Single-Channel Transmitter with optional IEEE 802.3at PoE power capability from 24VAC
- › Single or Dual Channel Receiver

SPECIFICATIONS

Video

| | |
|-----------------------|----------------|
| Input Signal | 1V pk-pk 75Ω |
| Overload | >1.5V pk-pk |
| Bandwidth | 5 Hz - 6 MHz |
| Diff. Gain Error | <2% |
| Diff. Phase Error | <0.7° |
| Tilt | <1% |
| Signal-to-Noise Ratio | 67 dB |
| Max RG-59 Distance | 500m (1,640ft) |

Ethernet

| | |
|-----------|---|
| Interface | 10/100BASE-T(X) Ethernet, RJ-45 |
| Wire Type | 4-pair CAT5 or better |
| Data Rate | Switch Selectable: Downlink: 36Mbps 25Mbps 28Mbps 21Mbps Uplink: 11Mbps 4Mbps 9Mbps 3Mbps |
| PoE | 30W IEEE802.3at |

Electrical & Mechanical

| | |
|---------------------|---|
| Operating Power | Non-PoE: 12 - 36 VDC or 24 VAC, 2W PoE: 12 - 36 VDC or 24 VAC, 2W ¹ |
| Overload Protection | Automatic Resettable Solid-State Current Limiters |
| Circuit Board | Meets IPC Standard |
| Size (L × W × H): | |
| CL(T,R)VE1COAX/M: | 4.1 × 3.7 × 1.1 in. (10.4 × 9.4 × 2.8 cm) |
| CLTVE1COAXPOE/M: | 4.1 × 3.7 × 2.2 in. (10.4 × 9.4 × 5.6 cm) |
| CLRVE2COAX: | 6.1 × 5.3 × 1.1 in. (15.5 × 13.5 × 2.8 cm) |
| Shipping Weight: | <2 lb./0.9 kg |

Environmental

| | |
|-------------------|---|
| MTBF | >100,000 hours |
| Operating Temp | -40° C to +75° C |
| Storage Temp | -40° C to +85° C |
| Relative Humidity | 5% to 95% (non-condensing) ² |

[1] Power consumption does not include that of Powered Device(s) (PD)

[2] May be extended to condensation conditions

NOTE: In a continuing effort to improve and advance technology, product specifications are subject to change without notice.



ORDERING INFORMATION

| Part Number | Description |
|----------------------|---|
| CLTVE1COAX/M | Medium Size Surface Mount Analog and IP Video over COAX Transmitter |
| CLRVE1COAX | Medium Size Surface Mount Analog and IP Video over COAX Receiver |
| CLTVE1COAXPOE/M | Medium Size Surface Mount Analog and IP Video over COAX Transmitter with POE |
| CLRVE2COAX | ComFit 2 Channel Analog and IP Video over COAX Receiver |
| Included Accessories | DC Plug-in Power Supply, 90-264 VAC, 50-60 Hz (Included) |
| Options | 24VAC, 3A Power Supply (for use with CLTVE1COAXPOE/M model) DIN-Rail Mounting Adaptor Plate Kit - With Mounting Hardware (Optional, order model DINBKT1) |

TYPICAL APPLICATION

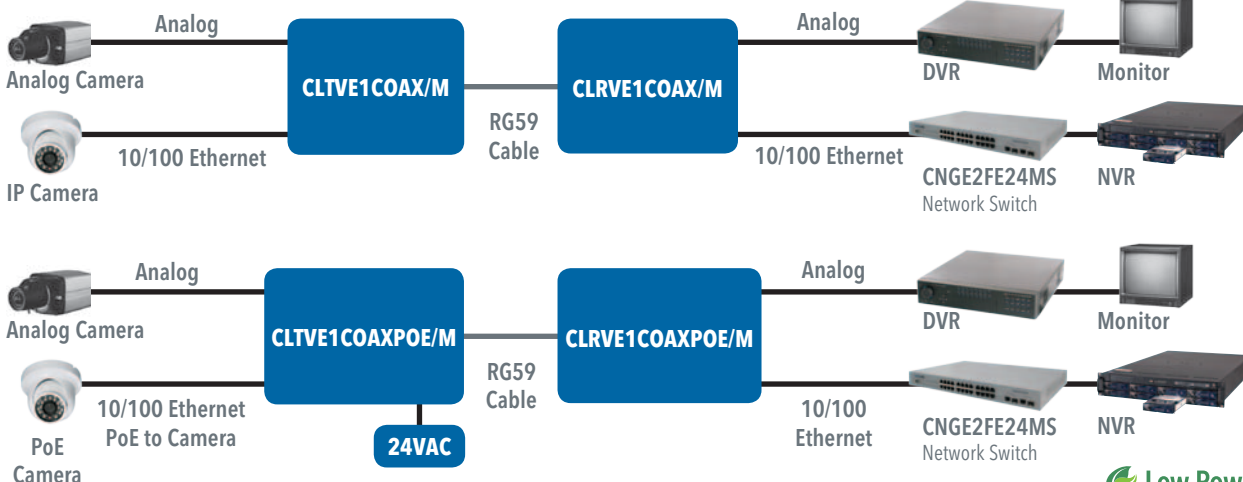

Low Power Consumption